

All dimensions are in MM. Unless otherwise stated for any doubt pls. ask.

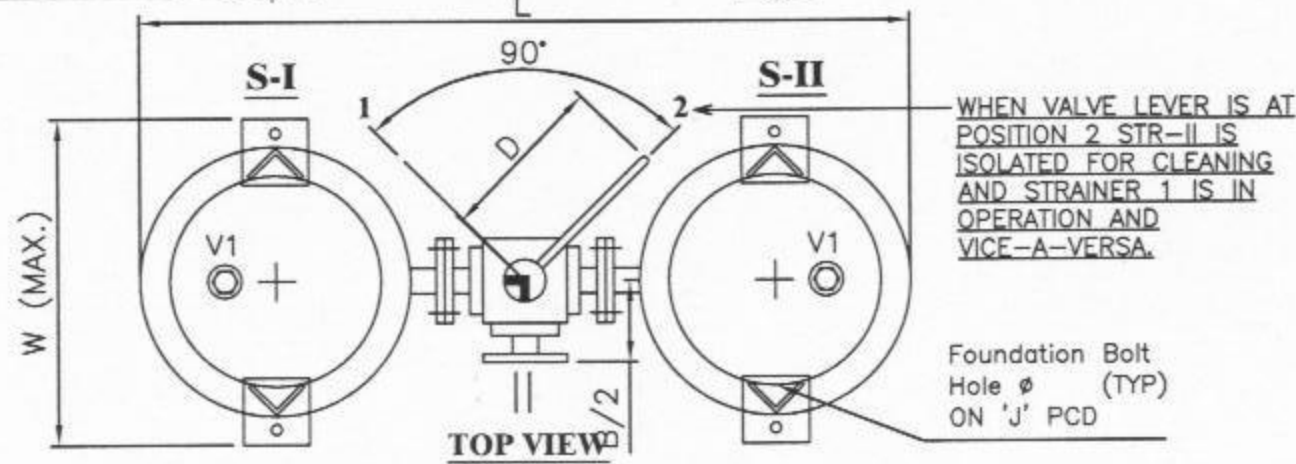
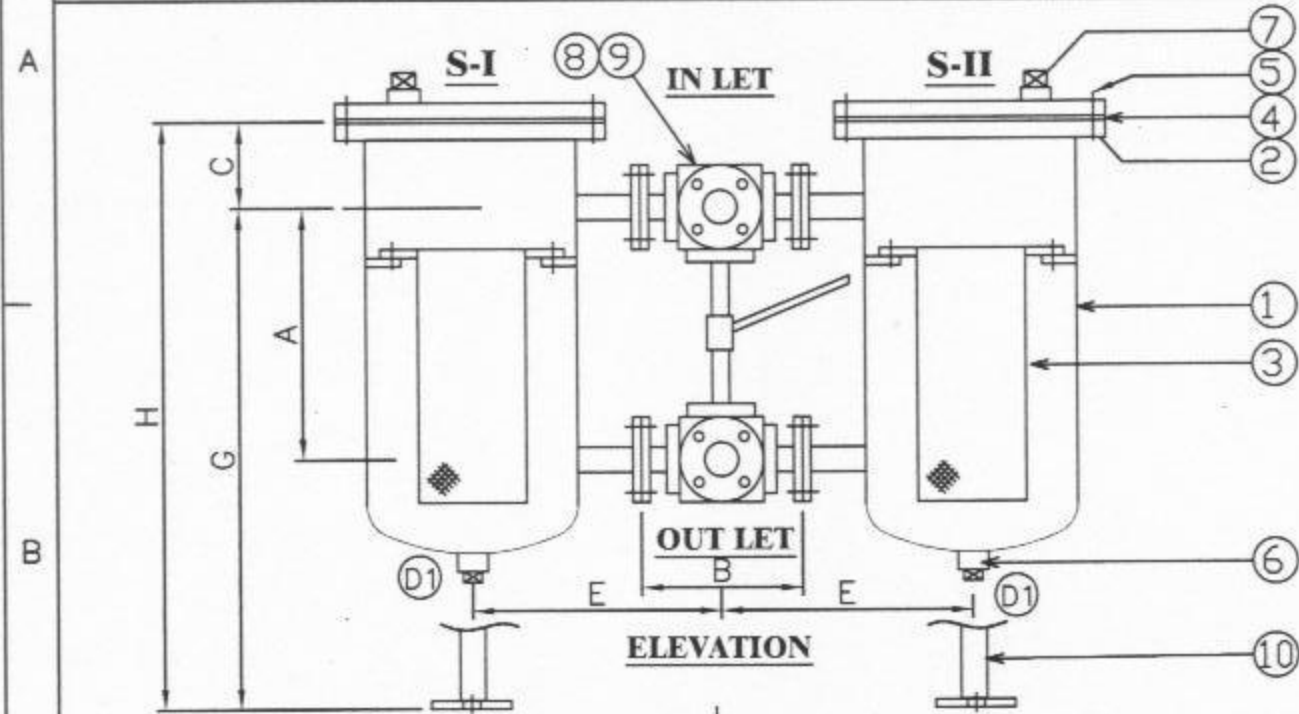

TECHNICAL DATA

MFG. STD. : MANUFACTURER
 INSPECTION STD. : API-598
 FLANGE END CONN. : ANSI B16.5-150# RF
 FLOW RATE
 HYD. TESTING : 10 Kg/cm² (g)

CLIENT :
 REF. NO. :

10	LEG SUPPORTS	
9	BALL/TRIMS PARTS	
8	3-WAY BALL VALVE	
7	AIR VENT PLUG-V1	
6	DRAIN PLUG-D1	
5	STUDS/NUTS	
4	GASKET	
3	SCREEN	
2	COVER/END FLG.	
1	SHELL/END NOZZLE	
SR. NO.	DESCRIPTION	MATERIAL SPECIFICATION

ENGINEERS COMBINE
 AHMEDABAD

DRN BY	TITLE	DUPLEX STRAINER FLANGE END ASA-150# RF
CHD BY		
APPR BY		
SCALE NTS	DRG. NO. SBD1-3B1	SH. 1 OF 1 REVISION 0

200	590	457	210	1200	560	1310	1570	1670				
150	520	394	180	1000	515	1120	1340	1520				
125	520	381	170	1000	480	1050	1250	1370				
100	460	350	150	900	450	960	1150	1320				
80	400	320	130	800	400	840	1010	1160				
65	350	300	130	700	350	730	890	950				
50	320	250	110	500	310	690	820	880				
40	275	215	100	400	265	630	760	760				
32	275	215	100	400	265	630	760	760				
25	220	175	80	400	200	530	630	660				
20	190	165	60	200	170	450	520	480				
15	190	165	60	200	170	450	520	480				
SIZE(NB)	A±3	B±5	C±3	D±10	E±3	G±5	H±15	L±10	W±10	J	ITEM NO	QTY Nos